

## FITTING INSTRUCTION

Clamp mark in acc. with		Cables joining
ISO	PN	
1	L	Left directional lights
2	+	Rear fog lights
3	31	Ground
4	R	Right directional lights
5	58R	Right side parking lights
6	54	Stoplights
7	58L	Left side parking lights

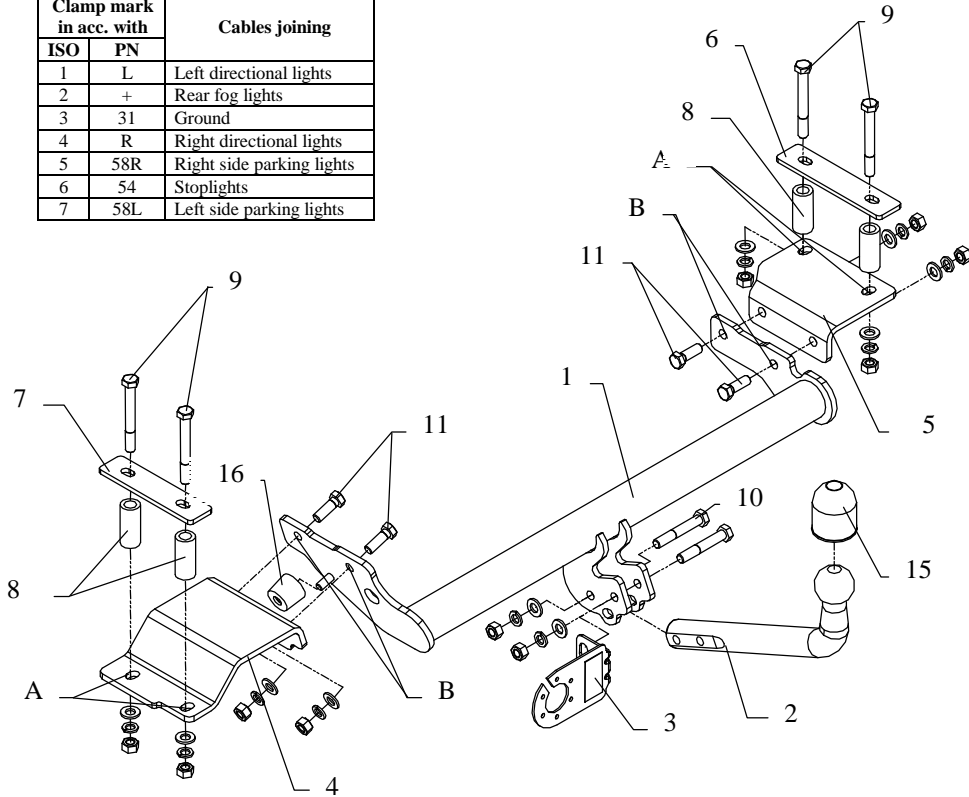

This tow bar is designed to assembly in following cars:  
**DAEWOO LANOS 3-5D** produced since 1997 till 2003, catalogue no. **X08** and is prepared to tow trailers max total weight **1100** kg and max vertical load **50** kg.

### *From manufacturer*

Thank you for buying our product. Their reliability has been confirmed in many tests. Reliability of tow bar depends also on correct assembly and correct exploitation. For this reasons we kindly ask to read carefully this instruction and apply to hints.

*The tow bar should be install in points described by a car producer.*

## The instruction of the assembly

1. Disassemble the rear plastic panel's cover in the boot
2. Put the template "A" on supports of the boot (left and right side), then sign huge hole according to this template and drill it.
3. Unslide the fuel pump and dismount the runner.
4. Being at the bottom of car drill 12 mm through original holes (apparently 20 mm) of chassis members to the inside part of the boot (two holes per each side, do it very careful)
5. Enlarge this holes fi 25 mm (do it inside of the boot) and next slip to this holes distance sleeves, see fig. 2
6. Put fish plate (pos. 6 and 7) in that way so holes in elements (pos. 6 and 7) agree to early make holes.
7. Put elements (pos. 4 and 5) at the bottom of car and fix it through distance sleeves and elements pos. (pos. 6 and 7) using bolts M12 x 100.
8. Fix bar of tow bar (pos. 1) through holes (pos. B) using M12x35mm to mounted elements (pos. 4 and 5)
9. Reassemble fuel pump` s runner through the hole signed at the fig. 3, then slide fuel pump and fix it to the handle of body car using link (shape of link is as the letter "Z") (pos. 17) from the car equipment
10. Reassemble rear plastic panel cover. Fix tow-ball (pos. 2) and socket plate (pos. 3) using bolts M12x75mm (pos. 10) from equipment.
11. Tighten all bolts according to the torque shown in the table.
12. Connect electric wires of 7-bolts socket according to the instruction of the car. (Recommend to make at authorized service station)
13. Complete paint layer damaged during installation.

Torque settings for nuts and bolts (8,8):

<b>M6</b> - 11 Nm	<b>M8</b> - 25 Nm	<b>M10</b> - 50 Nm
<b>M12</b> - 87 Nm	<b>M14</b> - 138 Nm	<b>M16</b> - 210 Nm







### NOTE

After install the towbar you should get adequate note in registration book (at authorised service station).The car should be equipped with:

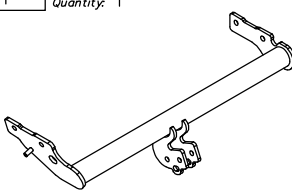
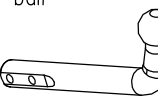
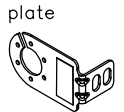
- Indicators
- Tow mirrors

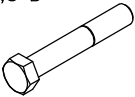
After 1000km of exploitation check all bolts and nuts. The ball of tow bar must be always kept clear and conserve with a grease.

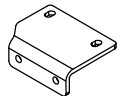
## Towbar equipment:

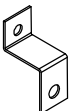
Pos. 1 Name: Main bar Quantity: 1	Pos. 6 Name: Right overlay Quantity: 1	Pos. 12 Name: Nut 8 B Quantity: 10 Dim.: M12
	Pos. 7 Name: Left overlay Quantity: 1	Pos. 13 Name: Plain washer Quantity: 10 Dim.: Ø 13 mm
Pos. 2 Name: Tow ball Quantity: 1	Pos. 8 Name: Distance sleeve Quantity: 4 Dim.: Ø25xØ13x57mm	Pos. 14 Name: Spring washer Quantity: 10 Dim.: Ø 12,2 mm
	Pos. 9 Name: Bolt 8,8 B Quantity: 4 Dim.: M12x100mm	Pos. 15 Name: Ball cover Quantity: 1
Pos. 3 Name: Socket plate Quantity: 1		
Pos. 4 Name: Left bracket Quantity: 1	Pos. 10 Name: Bolt 8,8 B Quantity: 2 Dim.: M12x75mm	Pos. 16 Name: Buffer gum. Quantity: 1
		
Pos. 5 Name: Right bracket Quantity: 1	Pos. 11 Name: Bolt 8,8 B Quantity: 4 Dim.: M12x35mm	Pos. 17 Name: Hypen Quantity: 1
		



**PPUH AUTO-HAK S.J.**

Produkcja Zaczepów Kulowych  
Henryk & Zbigniew Nejman  
76-200 SŁUPSK ul. Słoneczna 16K  
tel/fax (059) 8-414-414; 8-414-413  
E-mail: office@autohak.com.pl  
www. autohak.com.pl

## Towing hitch (without electrical set)

Class: **A50-X** Cat. no. **X08**

Designed for:

Manufacturer: **DAEWOO**

Model: **LANOS**

Type: **3-5D**

produced since 1997 till 2003

Technical data:

**D-value: 6,40 kg**

maximum trailer weight: **1100 kg**

maximum vertical cup load: **50 kg**

Approval number acc. to regulations EKG/ONZ 55.01: **E20-55R-01 0698**

## Foreword

This towing hitch is designed according to rules of safety traffic regulations. The towing hitch is a safety component and can be install only by qualified personnel. Any alteration or conversion of the towing hitch is prohibited and would lead to cancellation of design certification. Remove insulating compound and underseal from vehicle (if present) in the areas of the matting surfaces of the towing hitch. The vehicle manufacturer's specifications regarding trailer load and max. vertical cup mass are decisive for driving whereat values for the towing hitch cannot be exceeded.

*D-value formula:*

$$\frac{\text{Max trailer weight [kg]} \times \text{Max vehicle weight [kg]}}{\text{Max trailer weight [kg]} + \text{Max vehicle weight [kg]}} \times \frac{9,81}{1000} = D \text{ [kN]}$$